



CS-2002DC Series III

REMOTE CONTROL ALARM SYSTEM INSTALLATION & OPERATING INSTRUCTIONS

INTRODUCTION

CONGRATULATIONS on your choice of a Gargoyle™ Remote Alarm System by Crimestopper Security Products Inc. This booklet contains the information necessary for installing, using, and maintaining your alarm system. If any questions arise, contact your installation dealer or Crimestopper Security Products Inc. at the Tech Support number below.

***IMPORTANT INFORMATION: Primary and Optional Features:**

-PRIMARY: These are features that must be connected in order for the system to operate properly; i.e. the Siren, L.E.D., +12V Power, Ground, Doorpin, Override/Program/Valet Button etc.

-OPTIONAL: These are features to be connected if desired or agreed upon by the installing dealer. These features may also require additional parts and/or labor fees. Consult with your installer beforehand; i.e. Door Locks, Flashing Lights, Starter disable, Hood/Trunk trigger, and Auxiliary Remote Outputs etc.

TECH SUPPORT
Mon-Fri 8:00 AM-4:30 PM Pacific Time
(800) 998-6880

This device complies with FCC Rules part 15. Operation is subject to the following two conditions: 1) This device may not cause interference, and (2) this device must accept any interference that may be received, including interference that may cause undesired operation. The manufacturer is not responsible for any radio or TV interference caused by unauthorized modification to this equipment. Such modification could void the user's authority to operate the equipment.

TABLE OF CONTENTS

<i>Installation Cautions & Warnings</i>	2
<i>Control Module & Component Mounting</i>	3
<i>Wiring</i>	3-6
<i>Parking Light Jumper Diagram</i>	5
<i>Power Door Lock Wiring</i>	6-8
<i>Transmitter Programming</i>	9
<i>Option Programming</i>	10-12
<i>Programmable Option Reset</i>	13
<i>Custom Personal Override Code</i>	13
<i>Remote Control Diagram</i>	14
<i>Operating Instructions</i>	14-17
<i>2 Vehicle Operation</i>	17
<i>Car Jack Protection Features</i>	18
<i>LED, Shock Sensor & System Wiring Diagram</i>	19-20

INSTALLATION CAUTIONS & WARNINGS

BEFORE BEGINNING, check all vehicle manufacturer cautions and warnings regarding electrical service (AIR BAGS, ABS BRAKES, ENGINE COMPUTERS, BATTERY etc.).

WE RECOMMEND the use of a VOLT/OHM METER to test and verify wiring circuits. Test lights or illuminated probes can cause damage to on-board computer or engine management systems.

DO NOT exceed maximum output ratings.

WE RECOMMEND that the **MAIN SYSTEM FUSE** be **REMOVED** before jump starting, using a battery charger, or changing the battery. A voltage surge or high boost condition could damage alarm circuits.

DO NOT ROUTE ANY WIRING THAT MAY BECOME ENTANGLED with brake, and gas pedals, steering column, or any other moving parts in the vehicle.

CONTROL MODULE & COMPONENT MOUNTING

DO NOT Mount the control unit in the engine compartment or where the control unit or wiring harness where they can become entangled with moving parts such as brake/gas/clutch pedals, or the steering column! The alarm control module should be mounted in a concealed location. The Placement of the module will affect the distance from which the remote transmitter can control the unit. The antenna wire should be routed away from any metal if possible. Do not alter the length of the antenna wire or route it with other wires. Do not ground the antenna wire. Fasten the module to a bracket or wire harness using the cable ties provided. Under dash Mounting: If you are locating the control unit underdash, mount it as high as possible, not easily located by an intruder. Driver's Side Under dash mounting provides an easy location for wiring most of the system's connections, however this is a common location for an intruder to check for an alarm after breaking into the vehicle.

SIREN: Mount the siren under the hood to an inner fender-well, wheel-well, or other body surface with the open end facing downward. Run the red siren wire through the firewall using a rubber grommet. Ground the black to the body metal near the siren or you can use one of the siren's mounting screws for a ground.

LED: Mount the red LED in a visible location on the dashboard or console.

Shock Sensor: Mount the included shock sensor with wire ties to an under dash wire harness or fasten with screws to firewall or side paneling. Use the adjustment screw to set the sensitivity of the sensor. One screw adjusts both

Valet/Programming Button: Mount the Valet/Override/Program push-button in a hidden but accessible location. It is REQUIRED for emergency disarm, programming features and entering valet mode.

WIRING

GREEN WIRE: (-) DOOR TRIGGER

Identify the wire that reads ground when any door is open and 12 volts when all doors are closed. Some vehicles may have isolated door triggers. In this case you may need to run additional wires from other doors or go directly to the wire that triggers the vehicle's interior dome light. Sometimes newer vehicles contain a separate body control module (BCM) where the door trigger circuit can be located. One vehicle will not require the use of BOTH door trigger wires.

VIOLET WIRE: (+) DOOR TRIGGER

Same as the GREEN wire above except this wire is used for vehicles that show a positive voltage (12 volts) when the door is open and a ground when doors are closed as in many Ford, Lincoln, and Mercury vehicles.

WIRING

BLACK WIRE: SYSTEM CHASSIS GROUND

The Black wire **MUST** be connected the CHASSIS METAL of the vehicle. Scrape away any paint or debris from the connection point and use a star washer to ensure a good connection. Keep the ground wire short.

YELLOW WIRE: IGNITION SWITCHED “ON” AND “START” +12 VOLTS

Connect to an IGNITION wire (or fuse in the fuse box) that shows +12 Volts when the key in both “On” and “Start” (WHEN CRANKING) positions.

GRAY WIRE: (-) AUX REMOTE OUTPUT 1 (Optional, may require a relay)

Connect to the Negative trunk release circuit or to the activation circuit of an auxiliary module or device. If the circuit requires +12V, then a relay is required. RELAY WIRING: Connect the Gray wire to terminal 85, connect relay terminals 86 and 87 to +12V constant power. Connect terminal 30 of the relay to the +12V positive device/circuit to be activated.

BLUE WIRE: (-) HOOD/TRUNK TRIGGER (Optional)

Input trigger for a grounding hood or trunk pin switch. Connect to existing hood and trunk pin switches that read ground when open. If no existing switches are available, install new pin switches if desired. Note: DO NOT mount new pin switches in water pathways.

BLACK/WHITE WIRE: (-) DOME LIGHT ILLUMINATION OUTPUT (Optional, requires a relay)

This wire provides a (-) negative ground when the system is disarmed to activate a vehicles dome light circuit. We recommend the use of a relay for this connection. Connect Black/White to terminal #85 of relay. Connect terminal #86 to fused constant +12V. Connect terminal #87 to a +12V constant or ground source depending on the type of dome light circuit in the vehicle. Connect Terminal #30 to the dome light circuit in the vehicle.

BROWN/WHITE WIRE: (-) HORN PULSE / CHIRP OUTPUT (Optional, may require a relay)

Connect to the Negative Horn Trigger wire usually located near the steering column. If the vehicle horn circuit requires +12V, then a relay is required.

ORANGE WIRE: (-) NEGATIVE ARMED OUTPUT (500mA Ground, Optional)

This wire becomes a constant Ground output when system is armed. This output can be used to activate optional devices such as extra sensors, LED's, window roll-up modules, voice modules etc.

WHITE/RED WIRE: (-) AUX REMOTE OUTPUT 2 (Optional, may require a relay)

This wire connects the same way as Remote Output 1 see GRAY WIRE description on last page.

WIRING

BLUE/WHITE WIRE: (-) PASSENGER(S) DOOR UNLOCK OUTPUT (Optional, requires relay)

Connects to unlock circuit for passenger door(s) when using separate driver's door unlock option. See SEPARATE DRIVER'S DOOR UNLOCK WIRING on Page 8 for some configuration options.

BROWN WIRE: (+) SIREN OUTPUT (3 Amp Max.)

Connect to RED siren wire from the Siren in the engine compartment.

WHITE WIRE: PARKING LIGHT OUTPUT: +12V or (-) Negative Ground (Jumper Selectable)

Connect to switched +12V parking light wire at back of light switch. If this is not possible, connect directly to one of the parking lights at the front of the vehicle. If your vehicle requires a (-) Negative Ground signal to activate the parking lights, then you have to move the jumper located on the circuit board inside the unit. For European vehicles with separate right and left circuits, use a dual relay or 2 diodes to separate the output signal. The **DEFAULT** output is Positive. Carefully snap open the control module and see illustration below.

*CS-2002DC III Parking light output: The jumper plug inside the control module determines the unit's (+) or (-) Parking Light output. Use the jumper pin to select Positive or Negative Polarity Output. (*Default = Positive)*

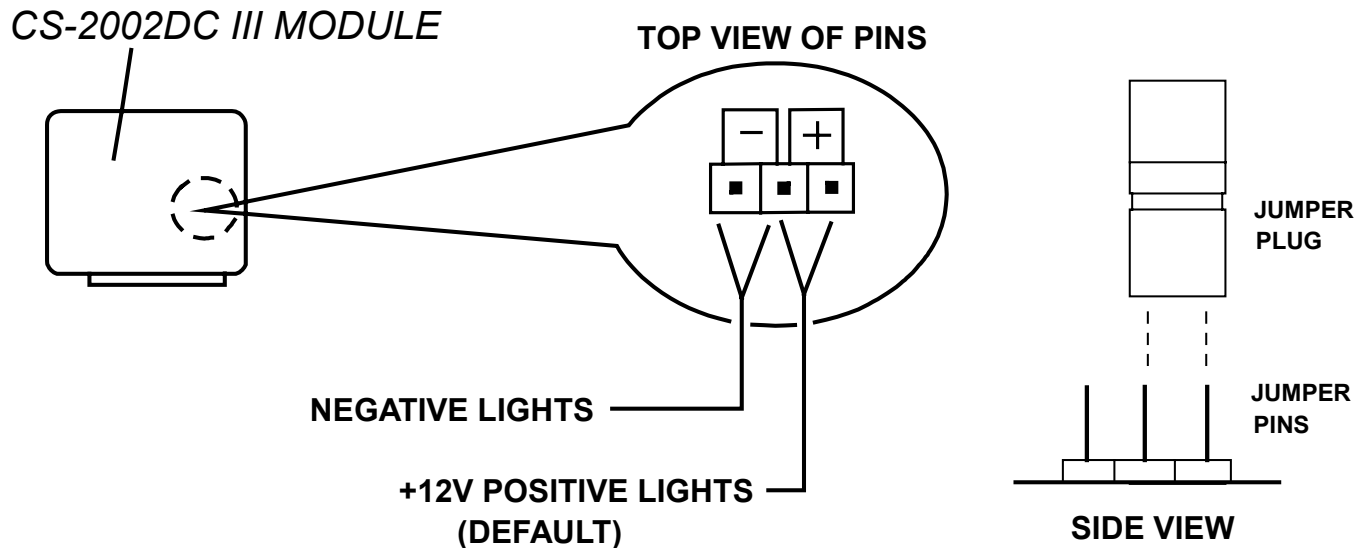

WIRING

RED WIRE: +12V POWER INPUT (15 amp fuse)

Connect to +12 Volt source with supplied fuse & holder. Recommended location for this connection is at the vehicle battery positive terminal.

14 GA. BROWN WIRE: (On-board Starter Disable Relay)

Cut the 14GA. Brown wire in half. Connect the 2 female terminals to the Male terminals on the CS-2002DC III control module. Cut the starter (Cranking only) wire on the vehicle. Connect the two brown wires to the 2 ends of the Starter wires. See SYSTEM WIRING DIAGRAM on PAGE 20

2 PIN PLUG (BLUE): PROGRAM/OVERRIDE PUSH BUTTON

Mount the Valet/Programming switch in a concealed but accessible location. This button is required when programming options and when an emergency override is required.

2 PIN PLUG (RED): LED INDICATOR (RED FLASHING LIGHT)

Mount the LED in a visible location of the dash or console.

4 PIN SENSOR PLUG/HARNESS (WHITE):

White Wire: Negative Warn-away

Blue Wire: Negative Trigger

Black Wire: Sensor Ground

Red Wire Sensor Power

SHOCK SENSOR: The sensor supplied with this system does not require any additional wiring. Simply mount the sensor in a suitable location, plug it in, and adjust the sensitivity. There are 2 LED's on the shock sensor to assist you in adjusting sensitivity. The Green LED indicates the "Warn Away" level and the Red LED indicates a full alarm shock sensor violation. The green screw adjusts "Warn Away" threshold and red screw adjusts the "Trigger" threshold.

POWER DOOR LOCK WIRING

3 PIN DOOR LOCK PLUG (Optional):

GREEN: (-) Negative pulse for LOCK

RED: +12V Coil Power for using relays.

BLUE: (-) Negative pulse for UNLOCK

Hint: Determine the type of locking system the vehicle has before connecting any wires. Incorrect connection could result in damage to the alarm and/or the vehicle's locking system.

POWER DOOR LOCK WIRING

NEGATIVE TRIGGER DOORLOCK WIRING

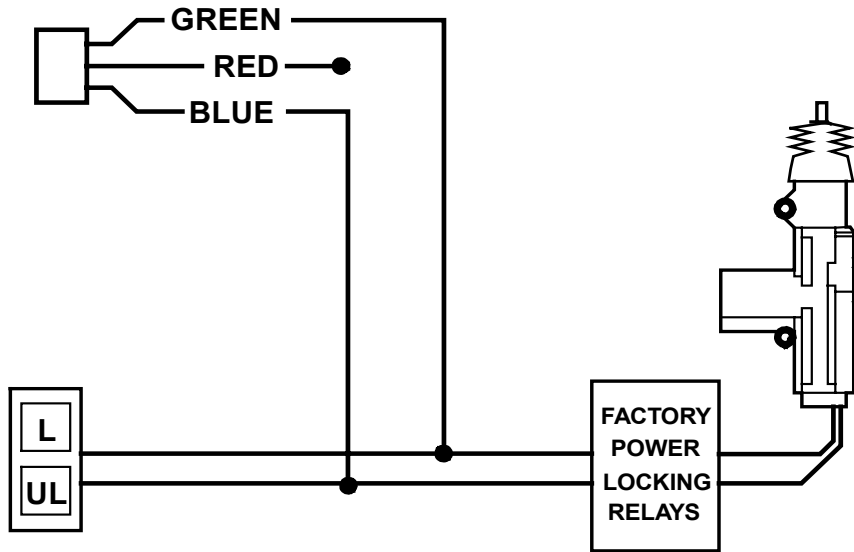

POSITIVE TRIGGER DOORLOCK WIRING

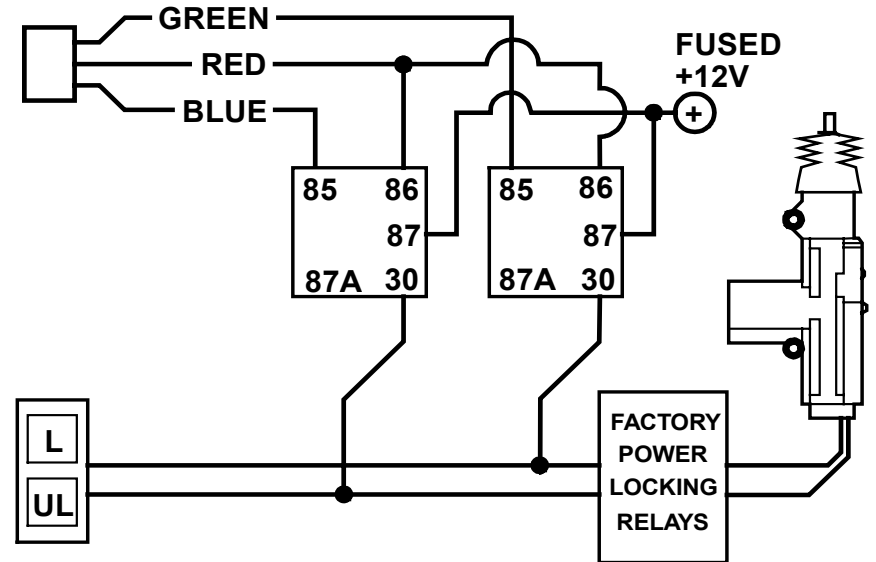

REVERSE POLARITY DOOR LOCK WIRING

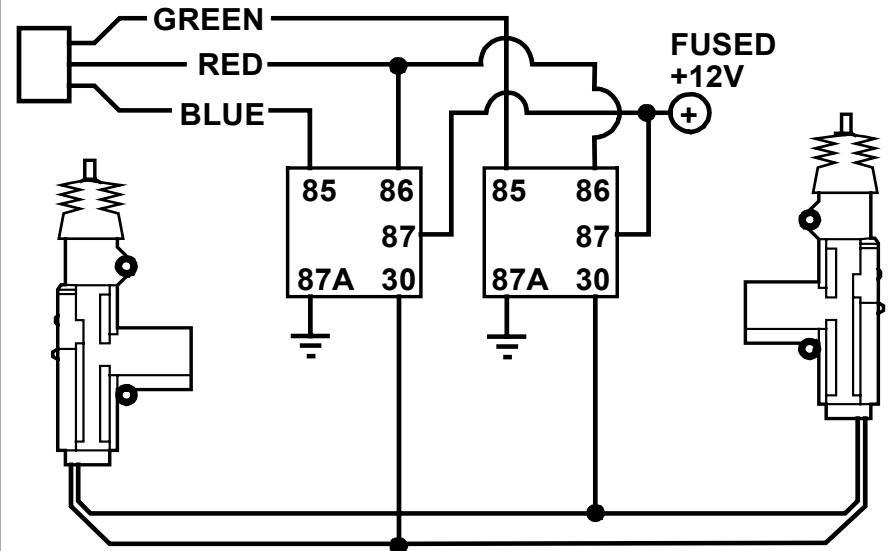
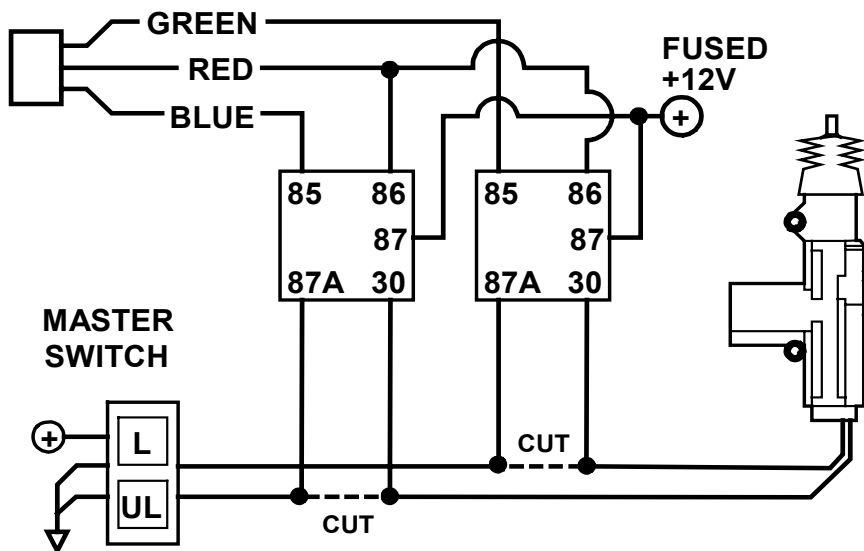

SEPARATE DRIVER'S DOOR UNLOCK WIRING

NEGATIVE TRIGGER DOOR LOCKS

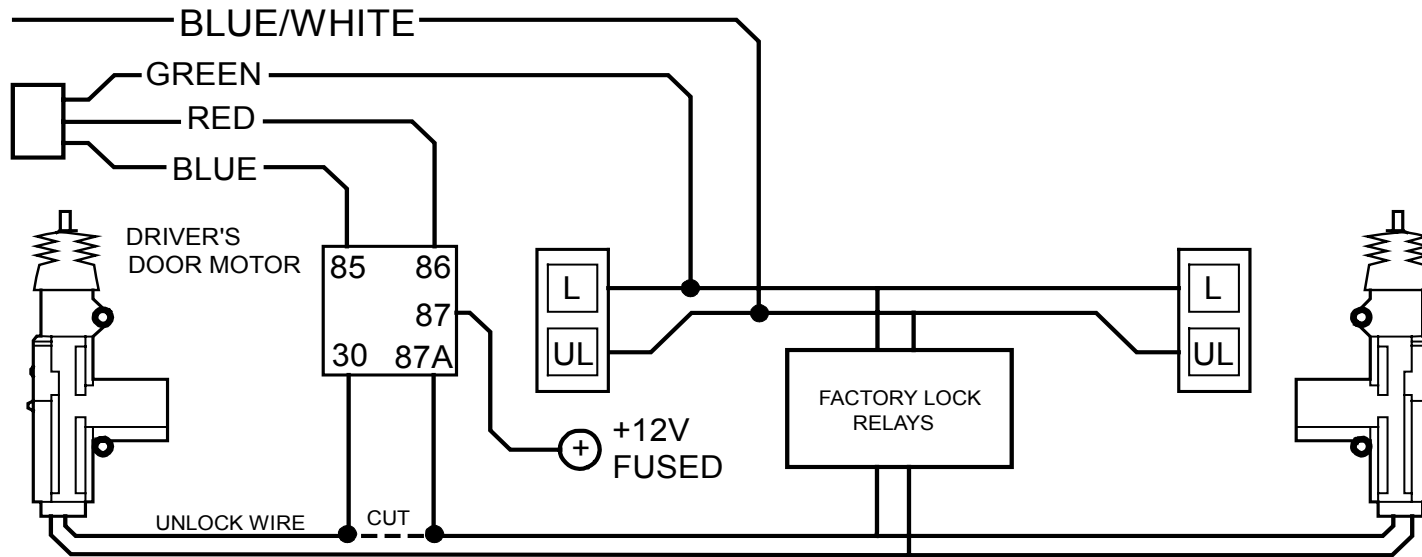

WIRING FOR REVERSE POLARITY DOOR LOCKS

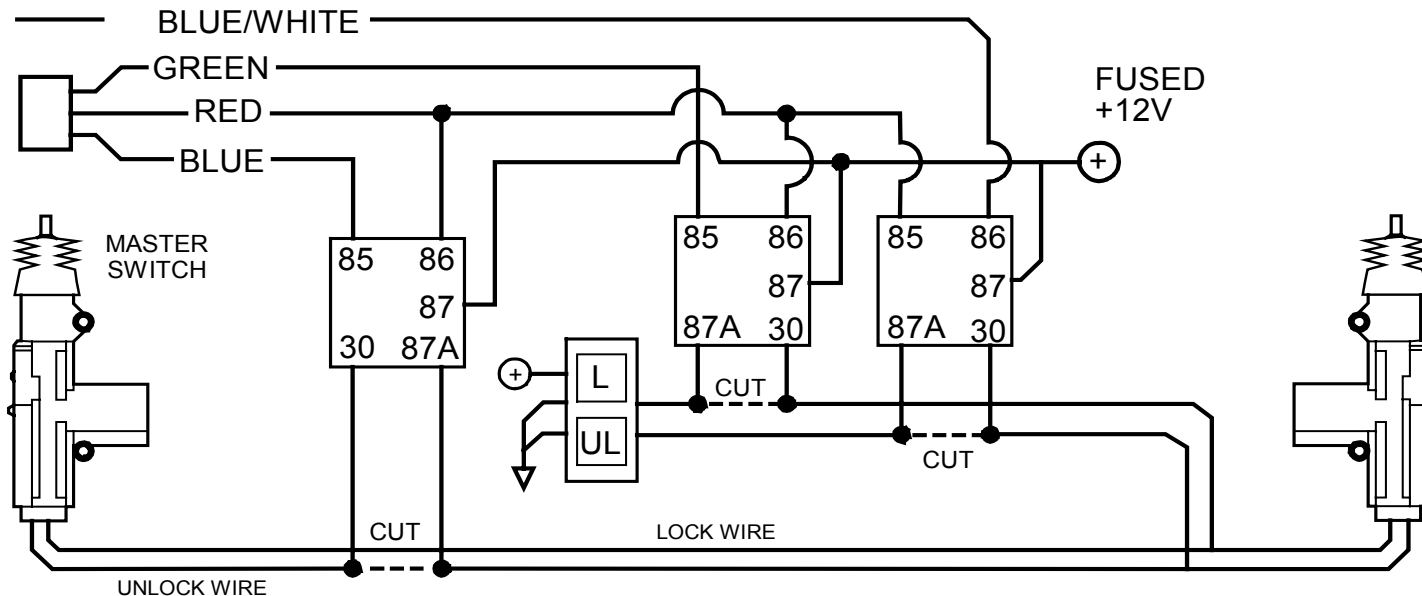

TRANSMITTER PROGRAMMING

This system will learn a maximum of 4 transmitters.

1. Turn Ignition ON/OFF...ON/OFF ...ON. You should hear (3) chirps.
2. Press the Program/Override Button 5 times and you should hear 5 light flashes and 5 siren chirps.
(System is now in transmitter programming mode.)
3. Press and release Button #1 on the remote. The siren will chirp once. Press Button #1 AGAIN, you should hear 2 chirps on the second press for code-learn confirmation. Sometimes it takes a 3rd press to get the remote to learn.
4. Repeat step #3 for up to 3 additional transmitters, or turn Ignition OFF. Siren will chirp 3 times and lights will flash 3 times when exiting the transmitter programming mode.

Note: If you are using CS-2002DC III identical alarms system in two vehicles, you can program button 4 (PANIC) from YOUR remote to ARM/DISARM the OTHER vehicle's alarm. Follow steps above at the OTHER vehicle, except press YOUR remote Button #4 (PANIC) 2 times in step #3 above. The other vehicle's alarm will learn YOUR Button #4 (PANIC). You can only ARM/DISARM the second vehicle. You cannot perform any other special or auxiliary functions on car #2.

DIAGRAM:

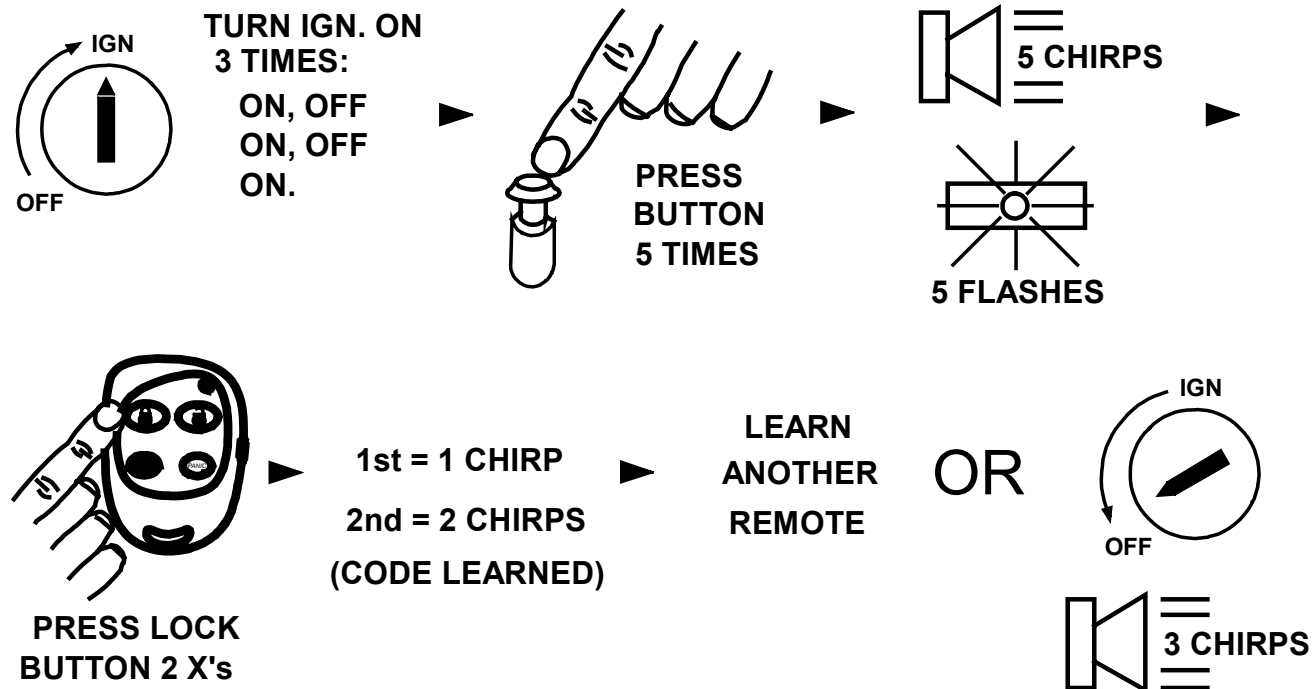

OPTION PROGRAMMING

1. Turn the Ignition ON and press the Override/Program button 5 times. You should hear a long chirp.
2. Within the next few seconds, press the Override/Program button [again] the number of times that corresponds to the feature list below. The siren will chirp for each button press. **DO NOT LOSE COUNT!!**
3. When you get to the desired option number, press the appropriate button on the transmitter according to the chart below. Turn Ignition off. See Below for Option numbers, descriptions, and values. (Button 1 gives a single light flash/chirp, Button 2 gives two light flashes/chirps, and Button 3 gives three light flashes/chirps.)
4. Change ONE option at a time repeating steps 1-3 as needed. When you are finished customizing options, check operation to see if the option(s) have changed.

PROGRAMMING OPTIONS CHART

* = Default Setting

Option #	Option Description	BUTTON 1 LOCK	BUTTON 2 UNLOCK	BUTTON 3 TRUNK
1.	Factory Horn Chirps / Pulses	Pulse with trip only	Arm/Disarm Chirps & Pulse with trip	Arm/Disarm/Warn Chirp & Pulse with trip *
2.	Passive Arming / Passive Chirp Countdown	ON	OFF*	Passive Arm with Chirp Countdown
3.	Passive Lock / Cust. Override	ON	OFF*	Custom Override
4.	Ignition controlled Locks	ON*	OFF	Ignition Lock Only
5.	10/60 Sec. Door Warning	10 Sec.	60 Sec.*	
6.	Active Re-Arm	ON*	OFF	
7.	Double Unlock Pulse	OFF*	ON	
8.	Silent Arm/Disarm (Chirp Defeat)	OFF*	ON	
9.	Parking Lights on with disarm	ON*	OFF	
10.	Disarm with trunk pop	OFF	ON*	
11.	Silent Arm/Disarm with quick press on Button #3.	ON*	OFF	
12.	Door Lock Pulse Time	0.7 Sec.*	3 Sec.	
13.	Type of Carjack Protection	ACTIVE*	PASSIVE	FULL-TIME
14.	Carjack Enable/Disable	DISABLE*	ENABLE	
15.	Arm/Disarm with IGN on (**Overrides Carjack functions)	DISABLED*	ENABLE**	

OPTION PROGRAMMING

1. HORN CHIRPS / PULSES

This option controls the system's Factory Vehicle Horn output. There are 3 selections: Button 1 (Lock) = Horn Pulse only when alarm is tripped. Button 2 (Unlock) = Horn Chirps for Arm / Disarm and Pulse when tripped. Button 3 (Trunk) = Horn Chirps for Arm, Disarm, and Pre-warning protection. All settings provide horn pulses when triggered.

2. PASSIVE ARMING / CHIRP COUNTDOWN

This option controls the Passive (Automatic) Arming feature. If ON, arming will occur 30 Seconds after the ignition is turned off and the last door has been closed. The LED will begin flashing rapidly while counting down. If a door is reopened, the system will wait (LED solid) for the door or zone to close before arming. The unit will chirp once and flash the lights once. Doors will lock if passive locking is selected. Factory default setting is OFF. If Passive Chirp countdown is selected, the System will produce a siren chirp every 2 seconds during countdown until the system arms.

3. PASSIVE LOCKS / CUSTOM OVERRRIDE (ALSO SEE CUSTOM OVERRRIDE SECTION, PAGE 13)

PASSIVE LOCKS: This option controls whether the doors will lock when Passive Arming occurs. Note: May increase the risk of locking keys in the vehicle. When selected ON the alarm will passively lock the doors when passive arming.

4. IGNITION-CONTROLLED LOCKS

This option controls whether the locks are controlled by Ignition. There are 3 selections: Button 1 (Lock) = Lock/Unlock with vehicle Ignition. Button 2 (Unlock) = No ignition locks. Button 3 (Trunk) = Ignition lock only. *Doors will not lock if they are open to prevent locking the keys in.*

5. 10 or 60 Sec. DOOR WARNING

This setting changes the delay time in which the alarm system begins to monitor the Door circuit. This option can prevent the alarm from giving warning chirps on vehicles with a delayed dome light.

6. ACTIVE RE-ARMING

Active Re-arming allows the system to re-arm itself 30 seconds after disarmed with the transmitter if a door has not been opened. This is handy if the vehicle is accidentally disarmed (via the Transmitter in your pocket) without you knowing it. If Chirp Countdown selected the system will chirp every 2 seconds during the 30-second count down to active re-arming.

OPTION PROGRAMMING

7. DOUBLE UNLOCK PULSE

With this feature enabled, the unit will send 2 unlock pulses when the #2 Unlock button is pressed. 2 pulses are required for interfacing into some existing Factory Keyless Entry or Alarm systems on vehicles such as Nissan, VW, Toyota, and Lexus vehicles.

8. SILENT ARMING /DISARMING (CHIRP DEFEAT)

With this feature, the system can be programmed to Arm and Disarm without the siren chirp using the regular Lock/Unlock Buttons. Flashing parking lights will be the only Arm/Disarm confirmation.

9. PARKING LIGHTS ON WITH DISARM

Keeps parking lights on instead of 2 flashes when system is disarmed to assist in locating your vehicle in a crowded parking lot or structure. Light will stay on for 30 Sec. or until Ignition is turned on.

10. DISARM WITH AUX. OUTPUT 1 (TRUNK POP)

Controls whether the system will or will not DISARM when the trunk pop or AUX. feature is used. When the feature is turned on the unit will DISARM when opening trunk or using an auxiliary device controlled by the Gray output wire.

11. SILENT ARM / DISARM WITH REMOTE BUTTON #3 (SHORT PRESS)

With this feature, the system can be programmed to Arm and Disarm without a siren chirp using a short press and release of Button #3 (TRUNK) on the remote transmitter.

12. DOOR LOCK/UNLOCK PULSE TIME

Controls the amount of time (0.75 sec. or 3 sec.) for the lock/unlock pulse. The 3 sec. setting may be required for 1980'/90's European Vehicles that require a long pulse to do Vacuum door lock systems.

13. ACTIVE, PASSIVE, or FULL-TIME CARJACK PROTECTION

This feature controls the type of Carjack protection the alarm will provide. There are 3 selections: Button 1 (Lock) = Active protection. Button 2 (Unlock) = Passive protection. Button 3 (Trunk) = Full-Time protection. Option number 14 must be enabled to allow Carjack functions to operate. See Operation : Carjack.

14. CARJACK FEATURES

This option controls the unit's Car Jack features. Enable or Disable Carjack (Turn ON or OFF) with this option.

15. ARM/DISARM WITH IGNITION ON

This option controls whether the unit will allow arming and disarm using the remote when the ignition is on (or vehicle is running). This program option may need to be enabled when using an Add-on remote starter to allow the alarm to be armed or disarmed after remote engine starting.

PROGRAMMABLE OPTION RESET

Follow the steps below to reset ALL OPTION VALUES ON PAGE 10 TO FACTORY DEFAULT SETTINGS.

1. Turn the Ignition ON and press the Override/Program button 5 times. You should hear a long chirp.
2. Immediately press Button #3 (Trunk) on the remote.
3. The siren will chirp 4 times and lights will flash 4 times.
4. Turn off ignition and all programming options should be restored to * values. (See page 10)

CUSTOM PERSONAL OVERRIDE CODE

Custom override allows the user to set a specific number of button presses (2-15) required to perform an emergency override/disarm of the alarm system. This increases the level of security of the system, but you **MUST MEMORIZE** how many button presses you have changed your system to use or the unit will not disarm in an emergency.

1. Enter programming mode. (See step #1 on page 10)
2. Press program button three times to go to option #3 "Passive Locks/Custom Override".
3. Press the Button #3 (TRUNK) on the remote transmitter.
4. Press and release the program again the number of times you desire in order to perform emergency disarm on this alarm system. Press the program button 2-15 times only.

To test feature: Trip alarm system, turn key ON, press the program/valet button 2-15 times as programmed above then continue to HOLD DOWN valet button on the LAST PRESS for 5 seconds. Alarm should disarm. If system does not disarm, then disarm with the remote transmitter and try again. If system still does not disarm, then repeat steps above.

OPERATING INSTRUCTIONS

5 BUTTON REMOTE TRANSMITTER:

BANK #1 (Directly Press Buttons)

Button 1: **Arm**

Button 2: **Disarm**

Button 3: **Aux #1 (Trunk)**

Button 4: **Panic**

Button 5: **(Change to BANK #2)**

BANK #2 (Press Button 5 FIRST, then within 3 seconds Buttons 1-4)

Button 1: **Silent Arm (No Chirp)**

Button 2: **Silent Disarm (No Chirp)**

Button 3: **Car Locator (5 successive Chirps)**

Button 4: **Aux #2**

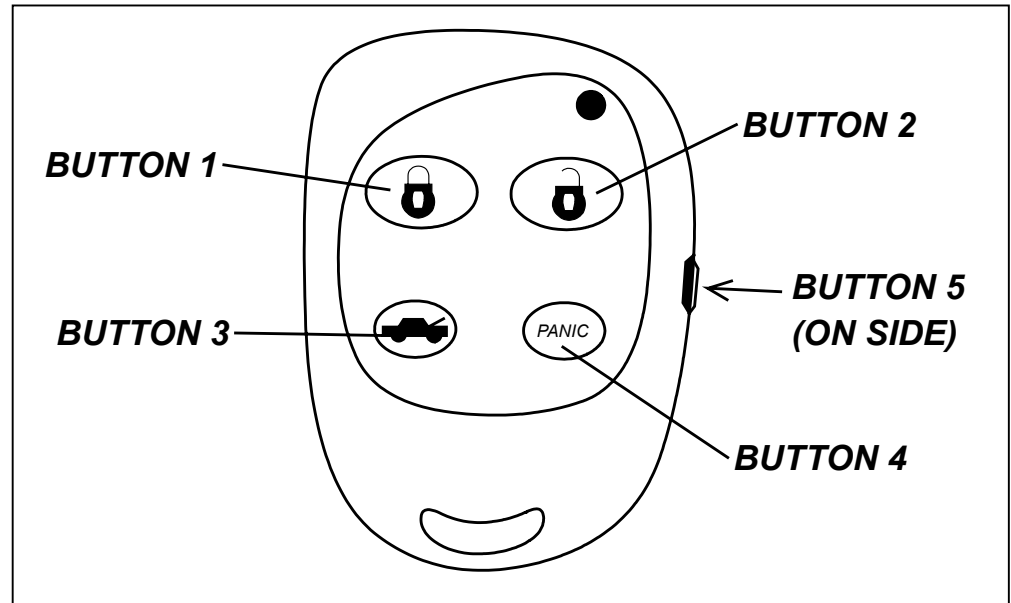

***GREEN LED Blinks once for Bank #1 and twice for Bank #2.**

ACTIVE ARMING

To arm the alarm and lock the doors, press the #1 (Lock Symbol) button on the transmitter. You will hear a single siren chirp and the lights will flash once. The system will arm, the doors will lock and the starter will be disabled if these optional features are installed. The red LED in the vehicle will start flashing after 15 seconds. After a short delay to allow vehicle and electronics to stabilize the system will be completely armed.

ALARM TRIGGERING

If there is an intrusion into the vehicle or hard impact to the body will sound the alarm and flash the lights for 45 seconds. After 45 seconds the system will automatically shut off and re-arm to continue to protect the vehicle. If a door is left open, the unit will cycle a second time and still continue to protect the other un-tampered zones.

DISARMING

Press the #2 (Unlock) button on the transmitter to disarm the alarm. You will hear 2 siren chirps and the lights will flash twice. The LED stops flashing. Door will unlock and dome light will turn on if the options are installed.

OPERATING INSTRUCTIONS

TRUNK/HATCH POP (REMOTE AUX. OUTPUT 1, OPTIONAL)

To pop the trunk (if optional feature is installed), press Button #3 (Trunk Symbol) on the transmitter for at least 1½ seconds. *If the system is armed, pressing Button #3 may or may not trip the alarm system when opening the trunk depending on programming option (10). See page 10.*

REMOTE PANIC PROTECTION

To sound the alarm upon command (panic), press and hold the Button #4 (Panic) for at least 2 seconds until the siren sounds. Press Button #2 (Unlock) to reset panic mode.

PRE-WARNING SHOCK PROTECTION & SENSOR ADJUSTMENT

If a low-level shock to the vehicle is detected, pre-warning protection will activate sounding 6 quick siren chirps and 1 light flash. If a hard impact is detected the shock sensor should trip the alarm system. Once it is mounted, adjust the sensor as needed by turning the adjustment screws clockwise to increase or counter-clockwise to decrease the sensitivity. The sensor is also equipped with 2 small indicator lights to ease the adjustment process. Green light = Pre-warning disturbance (6 siren chirps). Red light = A full alarm trip.

SELECTIVE SILENT ARM/DISARM THROUGH REMOTE CONTROL

This system can be armed and disarmed without siren chirps on an “as needed” basis. Press and quickly Button #5 on the side of the remote first, then press either LOCK to UNLOCK to Arm or Disarm your system without chirps.

PROGRAMMABLE SILENT ARM/DISARM MODE

The system can be silently armed and disarmed as normal with Lock/Unlock Buttons, but no siren chirp. See alarm programming option (8) to enable or disable this feature. See page 10.

EMERGENCY OVERRIDE / DISARM

If you have lost the transmitter or it stops working for any reason and the Alarm is armed, you will have to open the door with the key, which will activate the alarm. Turn the ignition on and press the override/program button 4-5 seconds (until siren stops). The Alarm will disarm and enter the Valet mode, which allows you to use the vehicle until you can repair/replace the remote transmitter or have the alarm system checked.

OPERATING INSTRUCTIONS

EMERGENCY DISARM WITH CUSTOM OVERRIDE

If you have programmed your system for Custom Override, follow the same steps above (Emergency Override) while pressing the valet button 2-15 times as you have programmed. You must continue to hold the button down on the last press for 5 seconds. The Alarm will disarm and enter the Valet mode, which allows you to use the vehicle until you can repair/replace the remote transmitter or have the alarm system checked.

VALET MODE

To disable the Alarm system for vehicle service or otherwise, turn the ignition on and press the override/program button 4-5 seconds until the dash LED turns on solid and you hear (1) siren chirp. Repeat the process to exit VALET mode and the system will chirp (2) times and the LED will turn off. Lock/Unlock and AUX features will still operate in when in VALET mode.

PASSIVE ARMING / PASSIVE LOCK MODES / PASSIVE CHIRP COUNTDOWN

If programmed, passive (Automatic) Arming will occur 30 Seconds after the ignition is turned off and the last door has been closed. The LED will begin flashing rapidly while counting down. If a door is reopened, the system will wait (LED solid) for the door or zone to close before arming. The unit will chirp once and flash the lights once. Doors will lock if passive locking is selected. May qualify for insurance discounts-check with your agent or proprietor. When the Unit is programmed for Passive Chirp Countdown, the siren will chirp during passive countdown, as an audible warning that arming will occur. This siren will emit a chirp every 2 seconds as soon as the last door is closed until the system arms 30 seconds later.

PRIOR INTRUSION ALERT

If the system was tripped in your absence, the dash LED will be flashing rapidly. When the system is disarmed you will hear 3 chirps (and 3 light flashes). Carefully inspect your vehicle to see if there is any damage or a theft has occurred.

DOMELIGHT ILLUMINATION (OPTIONAL)

This feature turns on the vehicles dome light upon disarm for 30 seconds or until the key is inserted and turned on. This will provide illuminated entry to your vehicle at night or in dimly lit areas for added safety and security.

OPEN ZONE ALERT/BYPASS

If the system detects a faulty or open zone (Door left open) when the system is ACTIVELY ARMED, the siren will chirp 4 times along with 4 light flashes. The faulty zone will be automatically bypassed.

OPERATING INSTRUCTIONS

IGNITION-CONTROLLED DOORLOCKS

The doors will automatically lock when the ignition is turned on and will unlock when the ignition is turned off. This feature can be programmed on, off, or to lock the doors only. *Doors will not lock if they are open to prevent locking the keys in.*

ACTIVE RE-ARMING (FAIL-SAFE PROTECTION)

Active Re-arming means that the system will re-arm itself 30 seconds after disarmed with the transmitter if a door has not yet been opened. This is handy if the vehicle is accidentally disarmed (via the transmitter in your pocket) without you knowing it. This feature can also be turned off in programming option (4). If programmed for Passive Chirp Countdown, the unit will emit a chirp every 2 seconds until the system Active Re-arms.

2nd AUX. OUTPUT (REMOTE AUX. OUTPUT 2)

To activate the Second auxiliary output press Button #5 on the side of the remote first, then Press Button #4 (Panic) to activate AUX. channel #2. This output can be used to control optional add-on accessories such as Remote Engine Start Modules, Window Roll up/down modules, etc.

ARM/DISARM WITH IGNITION ON (PROGRAM OPTION #15)

This feature allows the system to be armed or disarmed while the ignition is in the ON position or vehicle is running. The feature is disabled by default and should not be used under normal operating conditions. In some rare instances where an add-on remote start module is used, this option can be enabled to allow the CS-2000 alarm to be armed or disarmed when the vehicle is remote started (Ignition ON).

2 VEHICLE OPERATION

2 VEHICLE CONTROL

Your remote control can be programmed to Arm/Disarm a second vehicle with an identical Crimestopper CS-2002DC Series III system installed. Follow the transmitter programming steps on the second vehicle. Instead of pressing the #1 Lock at step #3, press Button #4 (Panic) on YOUR existing remote. Your remote will now have arm/disarm control of the second vehicle with a quick press and release of your Button #4 (Panic). The second car will learn your remote's panic button for Arm/Disarm.

NOTES: When both vehicles are present, don't press the Panic button for too long or YOUR alarm system may trip. You can only arm & disarm the second vehicle. You cannot control any special features or Aux functions on the second car.

CARJACK PROTECTION FEATURES

ACTIVE CARJACK

This feature provides Active Carjack protection and must be enabled before use through Alarm programming option (14) See page 9. When the Ignition is on (vehicle is running), press button #4 (Panic). Parking lights will flash TWICE to confirm the Carjack countdown sequence. 90 Seconds later, the unit will begin a Carjack Cycle consisting of 15 seconds of pre-warning chirps turning into a full system activation with siren/flashing light pulses for up to 5 min. To reset Active Carjack, IGNITION MUST BE ON, then press Button #4.

PASSIVE CARJACK

This feature provides Passive Carjack protection and must be enabled before use through Alarm programming options (13) & (14). See page 9. We recommend this mode should only be used in serious situations. When the Ignition is on (vehicle is running), and a door is opened, the Carjack countdown sequence will be initiated. 90 Seconds later, the unit will begin a Carjack Cycle consisting of 15 seconds of pre-warning chirps turning into a full system activation with siren/flashing light pulses for up to 5 min. To reset Passive Carjack, IGNITION MUST BE ON AND DOORS MUST BE CLOSED, then press the override/program button (3) times.

FULL-TIME CARJACK

ONLY USE THIS MODE WHEN THERE IS AN EXTREME TREAT OF A CARJACK WITH YOUR VEHICLE. Full-time Carjack protection must be enabled before use through Alarm programming options (13) & (14). See page 10. EVERY TIME the Ignition is turned ON or a door is opened and closed with the Ignition ON, a Carjack countdown sequence will be initiated. 90 Seconds later, the unit will begin a Carjack Cycle consisting of 15 seconds of pre-warning chirps turning into a full system activation with siren/flashing light pulses for up to 5 min. You must reset the unit every time the IGNITION is turned on or a door is opened and closed when the ignition is on. To reset IGNITION MUST BE ON AND DOORS MUST BE CLOSED, then press override/program button (3) times.

NOTE: When FULL TIME CARJACK is in effect, it must be reset every time the key is turned on, Door is opened, before entering VALET mode, and before Programming options or transmitters! It is always in effect each time the Ignition is turned on and/or a door is opened with Ignition on!

LED / VALET POD & SHOCK SENSOR

LED / VALET BUTTON POD:

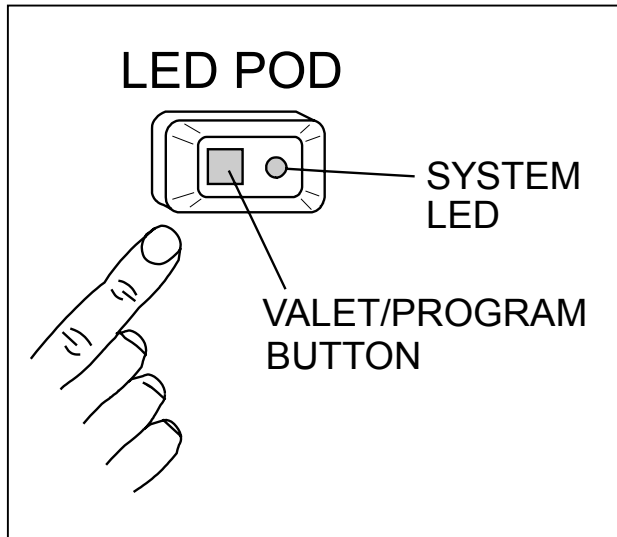

DUAL ADJUST Smart Sense™ Shock Sensor:

>Use the Green screw for Pre-warn adjustment

>Use the Red Level for Shock trigger adjustment

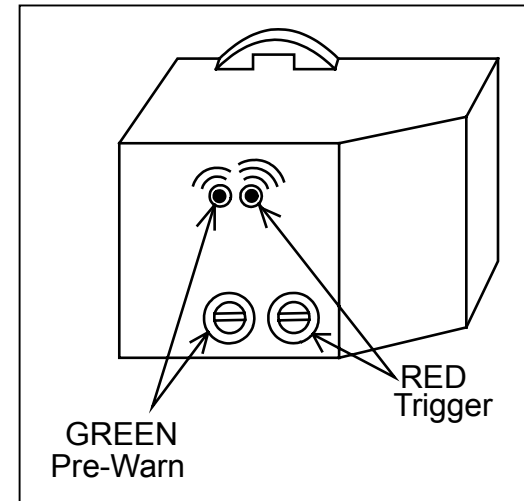

LED / VALET BUTTON MOUNTING:

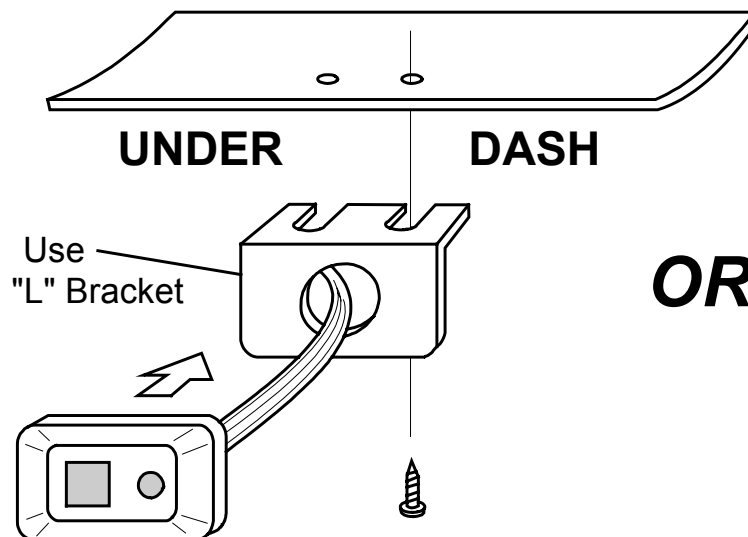

OR

